



台灣蓋科閥業股份有限公司
Taiwan Geko Valve Corporation

▶ 台灣蓋科閥業股份有限公司

地址:台中市后里區復興街36巷10號
電話: +886-4-25565626
傳真: +886-4-25569580
網址: www.geko.com.tw
郵箱: sales@geko.com.tw

▶ Taiwan Geko Valve corporation.

Address:NO.10, Ln.36, Fuxing St.,
Houli Dist., Taichung City 421, Taiwan
Tel: +886-4-25565626
Fax: +886-4-25569580
URL: www.geko.com.tw
E-mail: sales@geko.com.tw

▶ GEKO中國代表處

地址: 常州市青洋北路101號美吉特商務大廈16F
電話: 0519-85503155 / 85503955
傳真: 0519-85503133
網址: www.geko-valves.com
郵箱: geko@geko-valves.com

▶ GEKO office in China.

Address: 16th Floor Megete Building, No.101 Qiyang
North Road, Changzhou 213000, P.R.China
Fax: 0519-85503155 / 85503955
Fax: 0519-85503133
URL: www.geko-valves.com
E-mail: geko@geko-valves.com



www.geko-valves.com

High Performance
Butterfly Valve

高性能偏心蝶閥

台灣蓋科閥業股份有限公司
Taiwan geko valve corporation

+ 更多詳情資訊請登錄蓋科公司網頁或致電本公司

May. 2013. 3000



ABOUT GEKO FLUID CONTROL GmbH

經驗、責任和領先的技術



GV enterprise Co., Ltd. was found in 2002. GV consists of professional developers, designers, production personnel, and quality control personnel with years of experience. We devote all our energy to combine advanced technologies. We integrated CNC lathes, CNC internal machining, plastic injection, precision casting, aluminum and zinc die casting, and stamping mechanical equipment (Equipment with operating programs : Computer-aidedDesign→Purchase→Feed→Production Process→Assembly→Quality ControlService). Brand OEM integrates global resources intomarket, in order to provide better services for our customers.

Under strict quality control, TUV, ISO9001 quality assurance standards, and the pursuit of zero defect managements, they have made our OEM and ODM adopted by world renowned petrochemical industry, optoelectronics industry, biotechnology medical, semiconductor, and electronic chemical manufacturing .The current customers are Sinopec, PetroChina, CNOOC, China Shenhua, China Coal, China Guodian Corporation, China Car, Vietnam power plant, including GEKO, Omal, SFVetc. Our high self-request standards make us maintain the advantages of the international market, and ultimately our products will be widely used in the world-renowned enterprises, such as GE, TYCO, GEA, HITACHI, TOYO, POSCO, Samsung, ABB, TOTAL, BP, BASF, DOW, BAYER, ROCHE, LINDE, NOVARTIS, NESTLE, SYNGENTA, TATA STEEL.

In 2016, to meet diverse needs of the customers around the world, Germany GEKO buy shares into GV. We officially changed our name to Taiwan Geko Valve Corporation. We are in charge of the markets in Taiwan, Japan, Korea, and other countries in Southeast Asia and the agency of product sales network. Relying assembly and testing center in China, we will provide better services in Asian market.



台灣蓋科閥業股份有限公司

SPECIFICATIONS

> scope

> ALLICABLE STANDARDS

ANSI B16.5	ANSI B16.14
ANSI/FCI 70-2	MSS SP-25
MSS SP-61	MSS SP-68
API 598	API 609
API607	PED
ISO5208	ISO 5211
ISO 5752	ISO 9001

> DESIGN FEATURES

1. Double offset design for better performance
2. Bi-directional seal, non-leakage seat design
3. Low-friction bushing in up and down
4. Anti-static shaft
5. Special seat ring without screw end of sealing face
6. Anti-thrust washer for keeping disc center

> FEATURES

The design has been rigorously tested to meet industry performance requirements.

The fully supported one piece shaft with heavy duty metal bearings ensure perfect alignment of the seat and disc, for trouble free performance and long service life.

> MATERIALS

1. Stainless steel vavle: BODY-ASTM A351 CF8 CF8M DISC-ASTM A351 CF8 CF8M
2. Carbon valve: BODY-ASTM A105 CF8 A216 WCB DISC-ASTM A351 CF8 CF8M
3. Shaft: ASTM A564 Type 630(17-4PH) A182 F304 A182 F316

GKV-810 MATERIALS

Double-offset butterfly valve

Construction Details

- Stem (blowout proof): stainless steel stem with high strength, and good corrosion resistance. Designed per ISO 5211 standard.
- Stem Packing: V-ring PTFE provides positive sealing.
- Seat Retainer: Reliable multi-bolt retainer holds and supports the seat.
- Standard valves are suitable for bi-directional dead-end service at the full pressure/temperature rating of the valve.
- Body: Robust one-piece casting in WCB carbon steel or CF8M stainless steel. Available in wafer & lug style.
- Bearing: Full length provides maximum stem support.
- Thrust Ring: Centers the disc. Ensures tight shutoff and long service life.

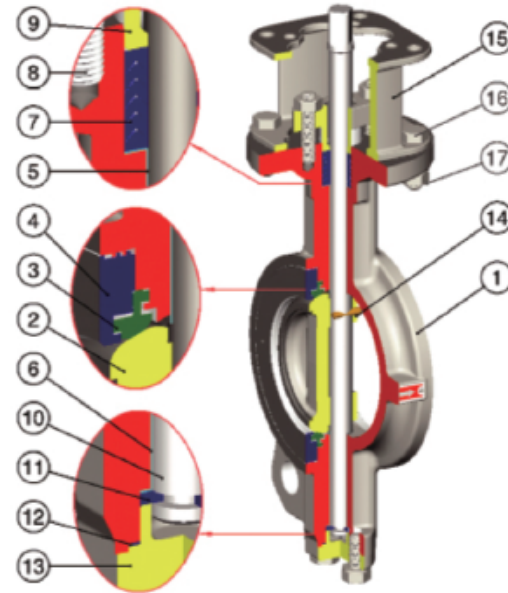

ANSI CLASS 150LB
ISO PN10-PN25
JIS 10K, 16K, 20K

NO.	Name	Materials	Specification		Remark	
			JIS	ASTM		
1	BODY	CARBON STEEL	SC480	A218 Gr. WCB		
		STAINLESS STEEL	SCS 13A	A351 Gr. CF8		
2	DISC	STAINLESS STEEL	SCS 14A	A351 Gr. CF8M	Disc edge has to be hard chrome plated when equipped RTFE seat	
			SCS 16A	A351 Gr. CF3M		
			SCS 13A	A351 Gr. CF8		
			SCS 14A	A351 Gr. CF8M		
3	TEFLON SEAT	PTFE			-29°C~160°C	
			PTFE+15%GLASS			-29°C~180°C
			PTFE+15%GRAPHITE			-29°C~210°C
4	RETAINER	STAINLESS STEEL	SCS 13A	A351 Gr. CF8		
			SCS 14A	A351 Gr. CF8M		
			SCS 16A	A351 Gr. CF3M		
5	BUSHING	PTFE+316SS				
6	BUSHING	PTFE+316SS				
7	PACKING	PTFE			-29°C~160°C	
			PTFE+15%GRAPHITE			-29°C~210°C
8	STUD	STAINLESS STEEL	SUS 304	A193 Gr. B8		
			SCS 13A	A351 Gr. CF8		
9	GLAND	STAINLESS STEEL	SCS 14A	A351 Gr. CF8M		
			SCS 16A	A351 Gr. CF3M		
10	STEM	STAINLESS STEEL	SUS 410	A182 Gr. F6a	Stem has to be hard chrome plated When equipped with PTFE + Graphite gland packing	
			SUS 304	A182 Gr. F304		
			SUS 316	A182 Gr. F316		
			SUS 630	A564 Gr. F630		
			XM-19	A479 Gr. XM-19		
			SUS 316	A240 Gr. 316		
11	THRUST RING	STAINLESS STEEL	SUS 316	A240 Gr. 316		
12	SEAL	PTFE				
13	BOTTOM COVER	STAINLESS STEEL	SCS 13A	A351 Gr. CF8		
			SCS 14A	A351 Gr. CF8M		
			SCS 16A	A351 Gr. CF3M		
14	PIN	CARBON STEEL	SC480	A216 Gr. WCB		
			SUS 316	A182 Gr. F316		
15	YOKE	DUCTILE IRON	FCD 450	A536 Gr. 65-45-12	For 24" valve only	
			CARBON STEEL	SC480	A216 Gr. WCB	Regualr
			STAINLESS STEEL	SCS 13A	A351 Gr. CF8	Option
16	BOLT	STAINLESS STEEL	SUS 304	A193 Gr. B8		
17	NUT	STAINLESS STEEL	SUS 304	A194 Gr. 8		

GKV-820 MATERIALS

Double-offset butterfly valve

Construction Details

- Stem (blowout proof): stainless steel stem with high strength, and good corrosion resistance. Designed per ISO 5211 standard.
- Stem Packing: Graphite provides positive sealing for fire-safe.
- Seat Retainer: Reliable multi-bolt retainer holds and supports the seat.
- Standard valves are suitable for bi-directional dead-end service at the full pressure/temperature rating of the valve.
- Body: Robust one-piece casting in WCB carbon steel or CF8M stainless steel. Available in wafer & lug style.
- Fire-proof seat: Bi-directional seal soft seat for non-leakage.
- Bearing: Full length provides maximum stem support.
- Thrust Ring: Centers the disc. Ensures tight shutoff and long service life.

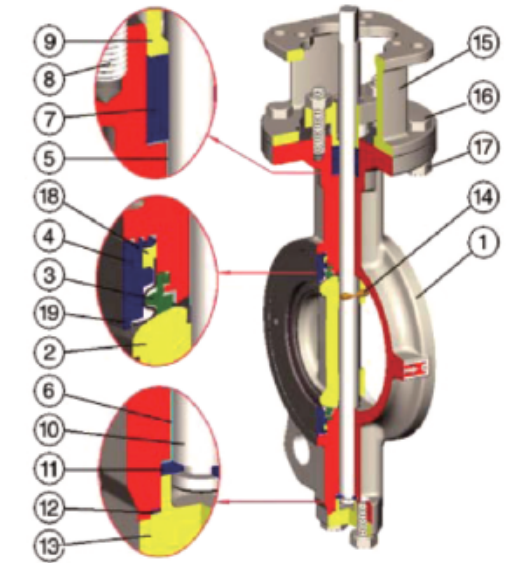

ANSI CLASS 150LB
ISO PN10-PN25
JIS 10K, 16K

NO.	Name	Materials	Specification		Remark	
			JIS	ASTM		
1	BODY	CARBON STEEL	SC480	A218 Gr. WCB		
		STAINLESS STEEL	SCS 13A	A351 Gr. CF8		
2	DISC	STAINLESS STEEL	SCS 14A	A351 Gr. CF8M	Disc edge equipped with hard chrome plated	
			SCS 16A	A351 Gr. CF3M		
			SCS 13A	A351 Gr. CF8		
			SCS 14A	A351 Gr. CF8M		
3	FIRE-SAFE SEAT	PTFE			-29°C~160°C	
			RPTFE			15% Glass fibre contained -29°C~160°C
			RPTFE			15% Graphite contained -29°C~160°C
4	RETAINER	STAINLESS STEEL	SCS 13A	A351 Gr. CF8		
			SCS 14A	A351 Gr. CF8M		
			SCS 16A	A351 Gr. CF3M		
5	BUSHING	PTFE+316SS				
6	BUSHING	PTFE+316SS				
7	PACKING	GRAPHITE				
8	STUD	STAINLESS STEEL	SUS 304	A193 Gr. B8		
9	GLAND	STAINLESS STEEL	SCS 14A	A351 Gr. CF8M		
			SCS 16A	A351 Gr. CF3M		
10	STEM	STAINLESS STEEL	SUS 410	A182 Gr. F6a	Stem equipped with hard chrome plated	
			SUS 304	A182 Gr. F304		
			SUS 316	A182 Gr. F316		
			SUS 630	A564 Gr. F630		
			XM-19	A479 Gr. XM-19		
			SUS 316	A240 Gr. 316		
11	THRUST RING	STAINLESS STEEL	SUS 316	A240 Gr. 316		
12	SEAL	GRAPHITE				
13	BOTTOM COVER	STAINLESS STEEL	SCS 13A	A351 Gr. CF8		
			SCS 14A	A351 Gr. CF8M		
			SCS 16A	A351 Gr. CF3M		
14	PIN	CARBON STEEL	SC480	A216 Gr. WCB		
			SUS 316	A182 Gr. F316		
15	YOKE	DUCTILE IRON	FCD 450	A536 Gr. 65-45-12	For 24" valve only	
			CARBON STEEL	SC480	A216 Gr. WCB	Regualr
			STAINLESS STEEL	SCS 13A	A351 Gr. CF8	Option
16	BOLT	STAINLESS STEEL	SUS 304	A193 Gr. B8		
17	NUT	STAINLESS STEEL	SUS 304	A194 Gr. 8		
18	PACKING	GRAPHITE				
19	METAL SEAT	STAINLESS STEEL	SUS 316	A240 Gr. 316	Nitrided	

GKV-830 MATERIALS

Construction Details

- Stem (blowout proof): stainless steel stem with high strength, and good corrosion resistance. Designed per ISO 5211 standard.
- Stem Packing: Graphite provides positive sealing.
- Seat Retainer: Reliable multi-bolt retainer holds and supports the seat.
- Standard valves are suitable for bi-directional dead-end service at the full pressure/temperature rating of the valve.
- Body: Robust one-piece casting in WCB carbon steel or CF8M stainless steel. Available in wafer & lug style.
- Bearing : Full length provides maximum stem support.
- Thrust Ring: Centers the disc. Ensures tight shutoff and long service life.

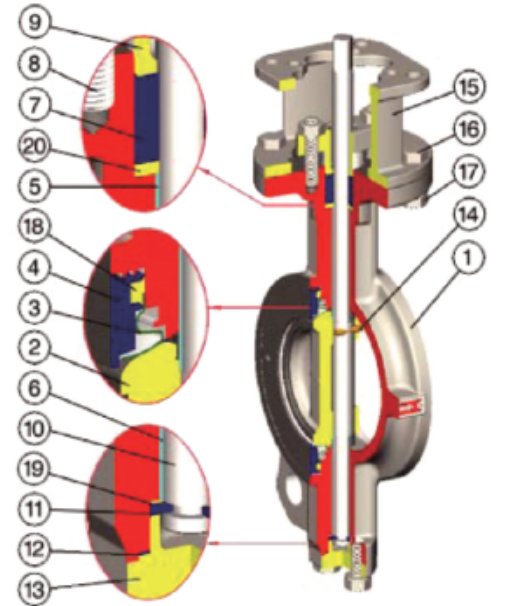

ANSI CLASS 150LB
ISO PN10-PN25
JIS 10K, 16K, 20K

NO.	Name	Materials	Specification		Remark
			JIS	ASTM	
1	BODY	CARBON STEEL	SC480	A218 Gr. WCB	
		STAINLESS STEEL	SCS 13A	A351 Gr. CF8	
2	DISC	STAINLESS STEEL	SCS 14A	A351 Gr. CF8M	Disc edge equipped with hard chrome plated
			SCS 16A	A351 Gr. CF3M	
			SCS 13A	A351 Gr. CF8	
3	METAL SEAT	STAINLESS STEEL	SCS 316	A240 Gr. 316	
4	RETAINER	STAINLESS STEEL	SCS 13A	A351 Gr. CF8	
			SCS 14A	A351 Gr. CF8M	
			SCS 16A	A351 Gr. CF3M	
5	BUSHING	STAINLESS STEEL	SCS 316	A182 Gr. F316	
6	BUSHING	STAINLESS STEEL	SCS 316	A182 Gr. F316	
7	PACKING	GRAPHITE			
8	STUD	STAINLESS STEEL	SUS 304	A193 Gr. B8	
9	GLAND	STAINLESS STEEL	SCS 13A	A351 Gr. CF8	Stem has to be hard chrome plated When equipped with PTFE + Graphite gland packing
			SCS 14A	A351 Gr. CF8M	
			SUS 410	A182 Gr. F6a	
			SUS 304	A182 Gr. F304	
			SUS 316	A182 Gr. F316	
10	STEM	STAINLESS STEEL	SUS 630	A564 Gr. F630	
			XM-19	A479 Gr. XM-19	
			SUS 316	A240 Gr. 316	
11	THRUST RING	STAINLESS STEEL	SUS 316	A240 Gr. 316	
12	SEAL	GRAPHITE			
13	BOTTOM COVER	STAINLESS STEEL	SCS 13A	A351 Gr. CF8	
			SCS 14A	A351 Gr. CF8M	
			SCS 16A	A351 Gr. CF3M	
14	PIN	CARBON STEEL	SC480	A216 Gr. WCB	
		STAINLESS STEEL	SUS 316	A182 Gr. F316	
15	YOKE	DUCTILE IRON	FCD 450	A536 Gr. 65-45-12	For 24" valve only
		CARBON STEEL	SC480	A216 Gr. WCB	Regular
		STAINLESS STEEL	SCS 13A	A351 Gr. CF8	Option
16	BOLT	STAINLESS STEEL	SUS 304	A193 Gr. B8	
17	NUT	STAINLESS STEEL	SUS 304	A194 Gr. 8	
18	PACKING	GRAPHITE	SUS 316	A240 Gr. 316	
19	WASHER	STAINLESS STEEL	SUS 316	A240 Gr. 316	
20	WASHER	STAINLESS STEEL	SUS 316	A240 Gr. 316	

SPECIFICATIONS

ANSI CLASS 150LB
ISO PN10-PN25
JIS 10K, 16K, 20K

ProCentric Double Offset

The first offset is between the center of stem and the center of the seat. The second offset is between the center of the valve and the center of the stem. This offset allows the disc to swing free of the seat in the open position. This pro-centric action reduces seat wear, and minimizes seating torque to create an eccentric seating action for high cycle applications.

Lip-type seal

Pressure assisted reinforced seats offer bi-directional bubble tight close off.

Fire Safe Seat

The seat ring is engineered to seal off pipeline flow in the event of a fire. In normal operation the seat with metal back up ring allows bi-directional bubble tight close off up to the full ANSI rating. In the event of a fire, if the fire destroys any part of the PTFE encapsulated seat, the inconel metal back up ring will stay in constant contact with the disc to provide a metal to metal back up seal. In emergency fire conditions, the line pressure is immediately reduced and the area is foamed to extinguish the fire.

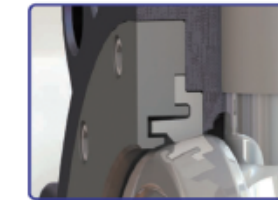

SEAT RATING (psig)

Size	Valve Open Degree										Temperature		Class 150	
	inch	mm	10°	20°	30°	40°	50°	60°	70°	80°	90°	"F	"C	PTFE
2.5"	65	1	11	27	40	60	83	106	133	140	-20 to 100	-29 to 38	285	285
3"	80	2	20	50	73	110	154	200	250	260	150	68	273	273
4"	100	4	32	80	120	180	250	320	400	420	200	93	260	260
5"	125	7	55	140	200	300	430	550	680	720	250	121	245	245
6"	150	11	90	230	340	510	710	910	1140	1200	300	149	230	230
8"	200	20	150	390	560	850	1190	1520	1900	2000	350	177	140	215
10"	250	30	240	600	870	1310	1840	2360	2940	3100	400	204	50	100
12"	300	40	360	920	1330	2000	2800	3600	4500	4750	450	232	0	0
14"	350	55	450	1130	1640	2500	3500	4500	5500	5850				
16"	400	75	650	1600	2300	3500	4900	6300	7850	8300				
18"	450	95	800	2000	2900	4400	6100	7900	9900	10400				
20"	500	125	1000	2700	3900	5900	8200	10500	13000	13800				
24"	600	200	1700	4400	6300	9500	13300	17000	21300	22500				

TORQUE CHART

ANSI CLASS 150LB
ISO PN10-PN25
JIS 10K, 16K, 20K

GKV-810 TORQUE DATA(KG-M) INCLUDING 30% SAFETY FACTOR

Size		Differential pressure (kg/cm ²)					
		0	5	10	15	20	25
2.5"	65	0.3	0.5	1.0	2.0	3.0	4.0
3"	80	0.5	1.0	2.0	3.0	4.5	6.0
4"	100	1.0	2.0	4.0	5.0	6.5	8.0
5"	125	2.0	4.5	6.5	9.0	11.0	13.0
6"	150	4.5	7.0	9.5	12.0	15.0	19.0
8"	200	7.0	11.0	15.0	18.5	21.5	24.0
10"	250	13.0	19.0	25.0	30.0	35.0	40.0
12"	300	20.0	30.0	40.0	50.0	58.0	65.0
14"	350	30.0	55.0	80.0	100.0	120.0	135.0
16"	400	45.0	70.0	100.0	120.0	140.0	160.0
18"	450	60.0	90.0	125.0	150.0	170.0	195.0
20"	500	85.0	120.0	150.0	175.0	210.0	240.0
24"	600	175.0	240.0	315.0	380.0	435.0	475.0

GKV-820 TORQUE DATA (KG-M) INCLUDING 30% SAFETY FACTOR

Size		Differential pressure (kg/cm ²)					
		0	5	10	15	20	25
2.5"	65	3	4	5	7	8	
3"	80	4	5	7	8	9	
4"	100	6	7	8	10	13	
5"	125	12	14	16	17	18	
6"	150	15	20	23	27	30	
8"	200	18	24	30	36	43	
10"	250	20	28	35	42	53	
12"	300	28	40	56	70	88	
14"	350	47	74	85	101	122	
16"	400	67	86	105	123	140	
18"	450	86	98	126	145	160	
20"	500	110	120	160	200	250	
24"	600	130	150	185	250	320	

GKV-830 TORQUE DATA (KG-M) INCLUDING 30% SAFETY FACTOR

Size		Differential pressure (kg/cm ²)					
		0	5	10	15	20	25
2.5"	65	4	5	8	10	13	
3"	80	5	7	9	12	14	
4"	100	8	10	12	16	18	
5"	125	10	13	14	17	20	
6"	150	14	16	17	18	21	
8"	200	21	26	30	34	38	
10"	250	25	29	33	36	40	
12"	300	26	40	51	60	69	
14"	350	50	69	88	101	125	
16"	400	65	84	104	127	150	
18"	450	80	99	122	153	173	
20"	500	110	120	160	200	250	
24"	800	130	150	185	250	320	

GKV-810/820/830 WAFER TYPE DIMENSION

ANSI CLASS 150
ISO PN10-PN25
JIS 10K, 16K, 20K

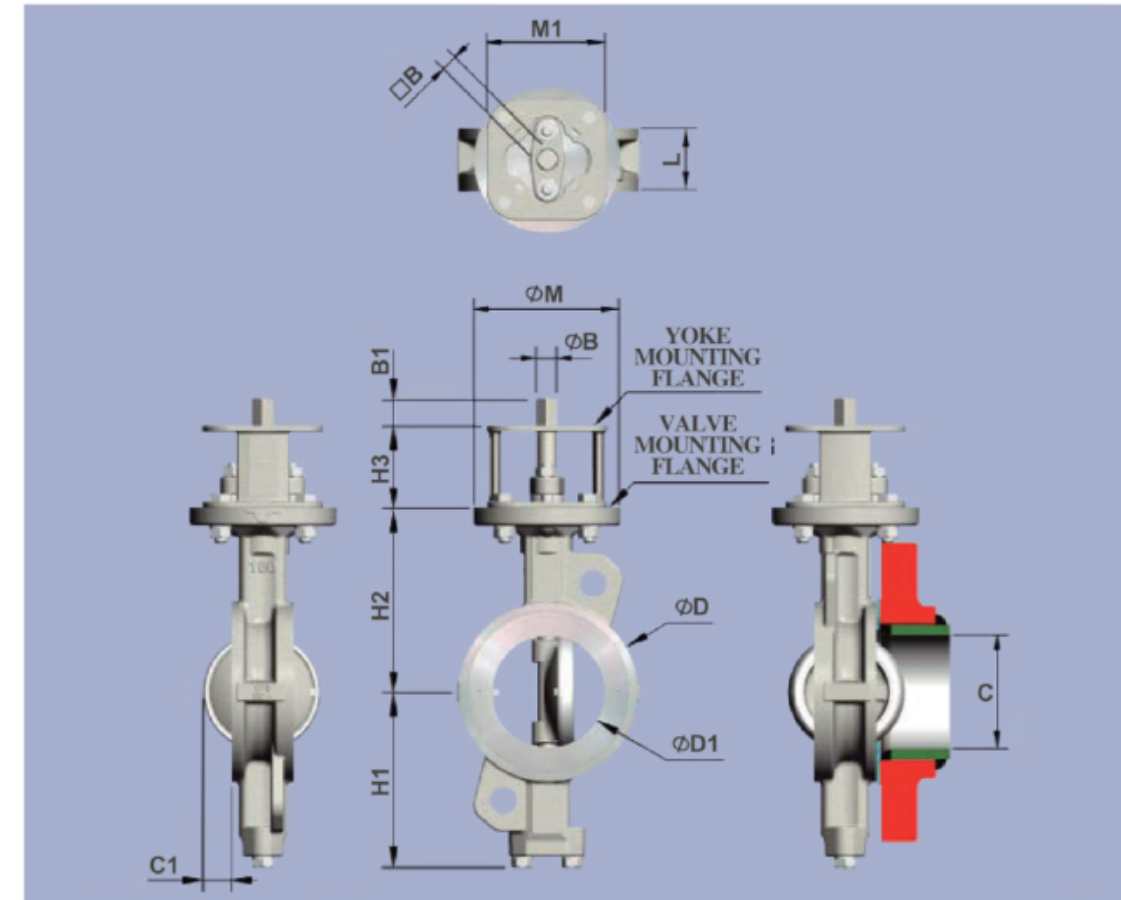

Unit:mm

Size	Face to Face	Dimensions								Mounting flange (ISO 5211)				Shaft end			Shaft pipe flange	Weight kg
		H1	H2	H3	φD	φD1	C	C1	Valve Type	φM	Yoke Type	M1	φB	□B	B1	★		
65	46	110	125	60	108	63	62.3	15	F07	90	F07	F05	70	14	11	18	ABCDEFGHIKMN	4.5
80	47	128	140	70	126	78	78	22	F10	125	F10	F07	102	18	14	23	ABCDEFGHIKMN	7
100	53	150	157	70	153	95	93	25	F10	125	F10	F07	102	18	14	23	ABCDEFGHIKMN	9
125	57	163	170	70	184	118	120	36	F10	125	F10	F07	102	22	17	23	ABCDEFGHIKMN	12
150	56	176	185	70	212	143	149	50	F10	125	F10	F07	102	22	17	23	ACDEFKMN	13.5
200	62	206	220	80	268	188	196	70	F12	150	F12	F10	125	25	19	28	ACDEFKMN	22
250	68	238	260	80	326	236	243	90	F12	150	F12	F10	125	28	22	28	ACDEFKMN	32
300	78	269	290	100	375	282	289	106	F14	175	F14	F12	160	35	27	37	ACDEFKMN	48
350	78/92	306	326	100	416	322	329	125	F14	175	F14	F12	160	36	27	37	ACDEFKMN	66
400	102	342	370	120	476	371	377	140	F16	210	F16	F14	195	48	36	47	ACDEFKMN	107
450	114	370	395	120	534	418	423	157	F16	210	F16	F14	195	48	36	47	ACDEFKMN	130
500	127	399	430	120	588	466	471	177	F16	210	F16	F14	195	60	46	56	ACDEFKMN	163
600	154	455	490	150	692	570	572	210	F25	300	F25	F16	300	60	46	56	ACDEFKMN	278

★ A:150LB B:300LB C:PN10 D:PN16 E:PN20 F:PN25 G:PN40 H:PN50 K:10K
M:16K N:B.S.10TABLE E P:20K

Pipe limit size >C

GKV-810/820/830 WAFER TYPE DIMENSION

ANSI CLASS 150
ISO PN10-PN25
JIS 10K, 16K, 20K

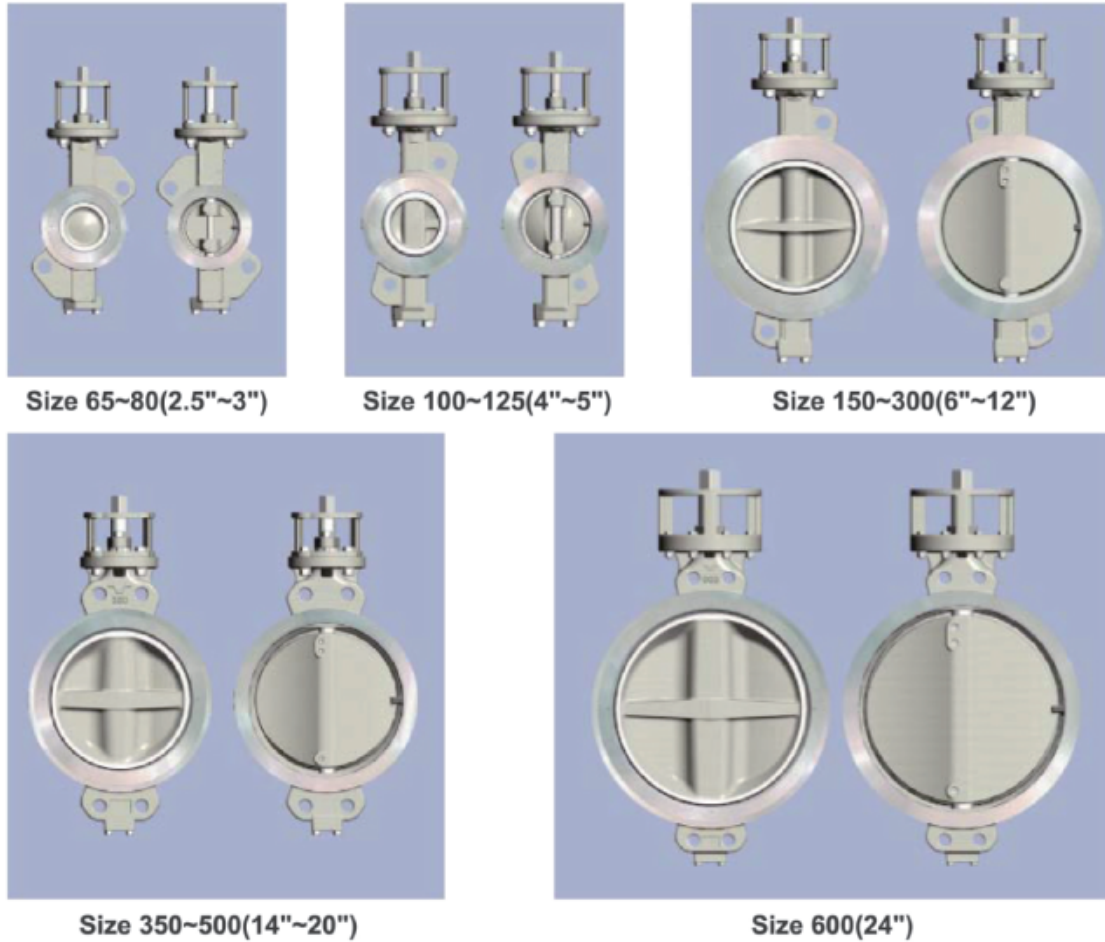

Unit:inch

Size inch	Face to Face L	Dimensions							Mounting flange (ISO 5211)				Shaft end			Weight LBS.	
		H1	H2	H3	φD	φD1	C	C1	Valve		Yoke		φB	□B	B1		
									Type	φM	Type	M1					
2.5	1.81	4.33	4.92	2.36	4.25	2.48	2.45	0.59	F07	3.54	F07	F05	2.78	0.55	0.43	0.71	10
3	1.85	5.04	5.51	2.76	4.96	3.07	3.07	0.87	F10	4.92	F10	F07	4.02	0.71	0.55	0.91	15
4	2.09	5.91	6.18	2.76	6.02	3.74	3.66	0.98	F10	4.92	F10	F07	4.02	0.71	0.55	0.91	20
5	2.24	6.42	6.69	2.76	7.24	4.65	4.72	1.42	F10	4.92	F10	F07	4.02	0.87	0.67	0.91	26
6	2.20	6.93	7.28	2.76	8.35	5.63	5.87	1.97	F10	4.92	F10	F07	4.02	0.87	0.67	0.91	30
8	2.44	8.11	8.66	3.15	10.55	7.39	7.72	2.76	F12	5.91	F12	F10	4.90	0.98	0.75	1.10	48
10	2.68	9.37	10.24	3.15	12.83	9.27	9.57	3.54	F12	5.91	F12	F10	4.92	1.10	0.87	1.10	70
12	3.07	10.59	11.42	3.94	14.76	11.10	11.38	4.17	F14	6.89	F14	F12	6.30	1.38	1.06	1.46	106
14	3.07/3.62	12.05	12.83	3.94	16.38	12.68	12.95	4.92	F14	6.89	F14	F12	6.30	1.42	1.06	1.46	145
16	4.02	13.46	14.57	4.72	18.74	14.61	14.84	5.51	F16	8.27	F16	F14	7.68	1.89	1.42	1.85	236
18	4.49	14.57	15.55	4.72	21.02	16.46	16.65	6.18	F16	8.27	F16	F14	7.68	1.89	1.42	1.85	286
20	5.00	15.71	16.93	4.72	23.15	18.35	18.54	6.97	F16	8.27	F16	F14	7.68	2.36	1.81	2.20	359
24	6.06	17.91	19.29	5.91	27.24	22.44	22.52	8.27	F25	11.81	F25	F16	11.81	2.36	1.81	2.20	612

Pipe limit size >C

GKV-813/823/833 LUG TYPE DIMENSION

ANSI CLASS 150
ISO PN10-PN25
JIS 10K, 16K, 20K

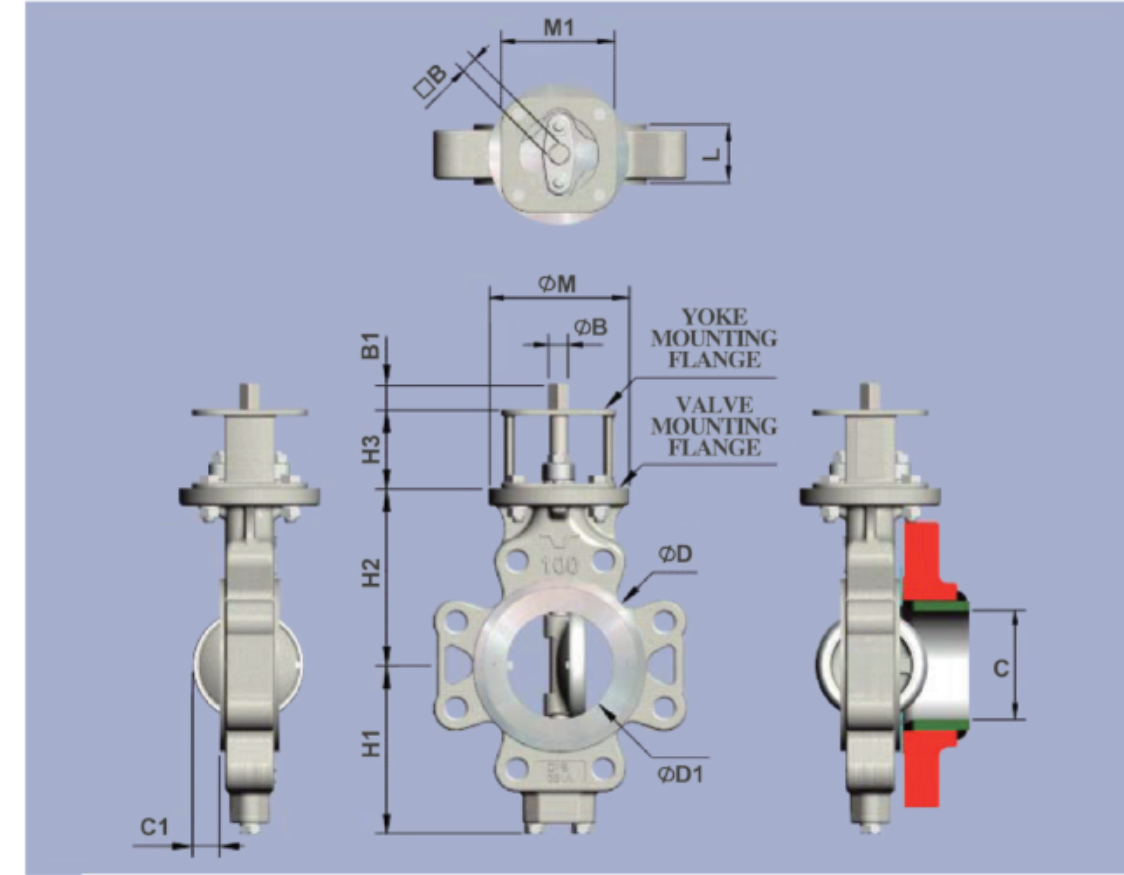

Unit:mm

Size mm	Face to Face L	Dimensions							Mounting flange (ISO 5211)				Shaft end			Suitable pipe flange ★	Weight kg	
		H1	H2	H3	φD	φD1	C	C1	Valve		Yoke		φB	□B	B1			
									Type	φM	Type	M1						
65	46	110	125	60	108	63	62.3	15	F07	90	F07	F05	70	14	11	18	AEKN	5.5
80	47	128	140	70	126	78	78	22	F10	125	F10	F07	102	18	14	23	AEN	8.5
100	53	150	157	70	153	95	93	25	F10	125	F10	F07	102	18	14	23	ABCDEFGHIKMN	14
125	57	163	170	70	184	118	120	36	F10	125	F10	F07	102	22	17	23	ABCDEFGHIKMN	18
150	56	176	185	70	212	143	149	50	F10	125	F10	F07	102	22	17	23	ACDEFKN	19.5
200	62	206	220	80	268	188	196	70	F12	150	F12	F10	125	25	19	28	ACEN	31
250	68	238	260	80	326	236	243	90	F12	150	F12	F10	125	28	22	28	ACDEFKMN	47
300	78	269	290	100	375	282	289	106	F14	175	F14	F12	160	35	27	37	ACDEN	67
350	78/92	306	326	100	416	322	329	125	F14	175	F14	F12	160	36	27	37	AEN	81
400	102	342	370	120	476	371	377	140	F16	210	F16	F14	195	48	36	47	ACDEFKMP	143
450	114	370	395	120	534	418	423	157	F16	210	F16	F14	195	48	36	47	AEN	163
500	127	399	430	120	588	466	471	177	F16	210	F16	F14	195	60	46	56	ACDEFKMP	230
600	154	455	490	150	692	570	572	210	F25	300	F25	F16	300	60	46	56	ACDEF	377

★ A:150LB B:300LB C:PN10 D:PN16 E:PN20 F:PN25 G:PN40 H:PN50 K:10K
M:16K N:B.S.10TABLE E P:20K

Pipe limit size >C

GKV-813/823/833 LUG TYPE DIMENSION

ANSI CLASS 150
ISO PN10~PN25
JIS 10K, 16K, 20K



Size 65~80(2.5"~3")



Size 100~125(4"~5")

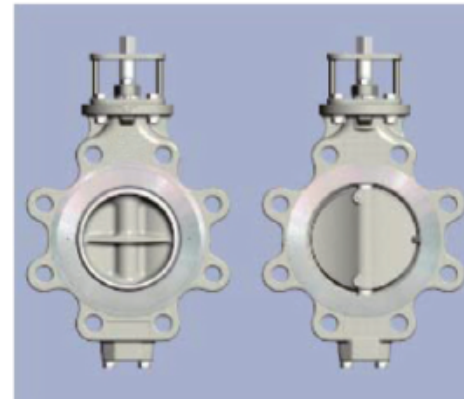

Size 150~200(6"~8")



Size 250~350(10"~14")



Size 400~450(16"~18")

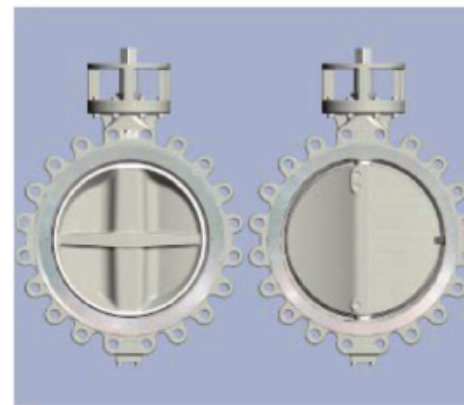

Size 500~600(20"~24")

Unit:inch

Size	Face to Face	Dimensions								Mounting flange (ISO 5211)				Shaft end			Weight
		L	H1	H2	H3	φD	φD1	C	C1	Valve		Yoke		φB	□B	B1	
inch										Type	φM	Type	M1				LBS.
2.5	1.81	4.33	4.92	2.36	4.25	2.48	2.45	0.59	F07	3.54	F07	F05	2.78	0.55	0.43	0.71	12
3	1.85	5.04	5.51	2.76	4.96	3.07	3.07	0.87	F10	4.92	F10	F07	4.02	0.71	0.55	0.91	19
4	2.09	5.91	6.18	2.76	6.02	3.74	3.66	0.98	F10	4.92	F10	F07	4.02	0.71	0.55	0.91	31
5	2.24	6.42	6.69	2.76	7.24	4.65	4.72	1.42	F10	4.92	F10	F07	4.02	0.87	0.67	0.91	40
6	2.20	6.93	7.28	2.76	8.35	5.63	5.87	1.97	F10	4.92	F10	F07	4.02	0.87	0.67	0.91	43
8	2.44	8.11	8.66	3.15	10.55	7.39	7.72	2.76	F12	5.91	F12	F10	4.90	0.98	0.75	1.10	68
10	2.68	9.37	10.24	3.15	12.83	9.27	9.57	3.54	F12	5.91	F12	F10	4.92	1.10	0.87	1.10	104
12	3.07	10.59	11.42	3.94	14.76	11.10	11.38	4.17	F14	6.89	F14	F12	6.30	1.38	1.06	1.46	148
14	3.07/3.62	12.05	12.83	3.94	16.38	12.68	12.95	4.92	F14	6.89	F14	F12	6.30	1.42	1.06	1.46	178
16	4.02	13.46	14.57	4.72	18.74	14.61	14.84	5.51	F16	8.27	F16	F14	7.68	1.89	1.42	1.85	315
18	4.49	14.57	15.55	4.72	21.02	16.46	16.65	6.18	F16	8.27	F16	F14	7.68	1.89	1.42	1.85	359
20	5.00	15.71	16.93	4.72	23.15	18.35	18.54	6.97	F16	8.27	F16	F14	7.68	2.36	1.81	2.20	507
24	6.06	17.91	19.29	5.91	27.24	22.44	22.52	8.27	F25	11.81	F25	F16	11.81	2.36	1.81	2.20	830

Pipe limit size >C

LEVER & GEAR OPERATED

VF-910 (WAFER TYPE)
VF-913 (LUG TYPE)

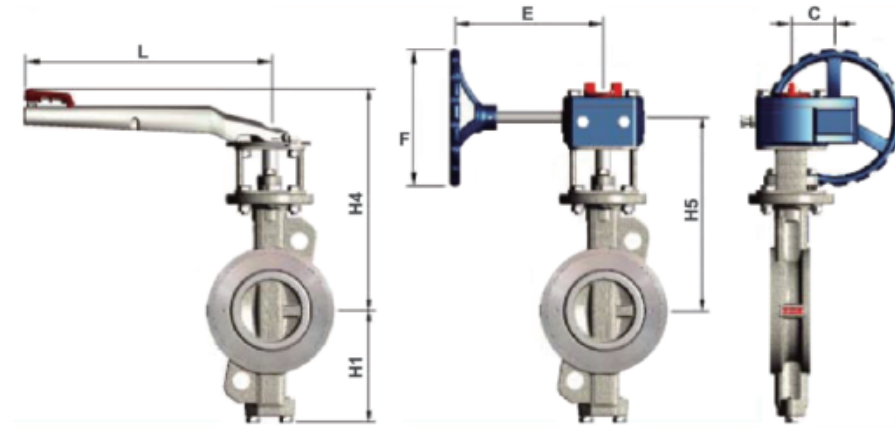

Size	Operator	Series no.	Lever operator				Gear operator						
			Dimensions		Weight(kg)		Dimensions				Weight(kg)		
mm	inch		H4	L	Wafer	Lug	H5	C	E	F	Wafer	Lug	
65	2.5	L7A	257	200	5.2	6.2	-	-	-	-	-	-	-
		C07	-	-	-	-	222	41	155	150	7.8	8.8	
80	3	L7B	282	250	7.8	9.3	-	-	-	-	-	-	-
		C07	-	-	-	-	247	41	155	150	10.3	11.8	
100	4	L7B	299	250	9.8	14.8	-	-	-	-	-	-	-
		C10	-	-	-	-	296.5	63	195	200	16.5	21.5	
125	5	L10	318	355	13.6	19.6	-	-	-	-	-	-	-
		C10	-	-	-	-	281.5	63	195	200	19.5	25.5	
150	6	L10	333	355	15.1	21.1	-	-	-	-	-	-	-
		C10	-	-	-	-	296.5	63	195	200	21	27	
200	8	L10	378	335	23.6	32.6	-	-	-	-	-	-	-
		C12	-	-	-	-	341	61	232	310	31	40	
250	10	C12	-	-	-	-	381	61	232	310	41	56	
300	12	C14	-	-	-	-	443	81	280	400	70	89	
350	14	C14	-	-	-	-	479	81	280	400	88	103	
400	16	A2	-	-	-	-	546	123	307	400	142	178	
450	18	A2	-	-	-	-	571	123	307	400	165	198	
500	20	A2	-	-	-	-	606	123	307	400	198	265	
600	24	A3+S3	-	-	-	-	785	160	370	400	387	486	

Size	Operator	Series no.	Lever operator				Gear operator						Handwheel turns ON/OFF N	Mounting flange (ISO 5211)		
			Dimensions		Weight(lb)		Dimensions				Weight(lb)			Type	PCD	
mm	inch		H4	L	Wafer	Lug	H5	C	E	F	Wafer	Lug		mm	inch	
65	2.5	L7A	10.19	7.87	11	14	-	-	-	-	-	-	-	F07	70	2.75
		C07	-	-	-	-	8.74	1.61	6.10	5.91	17	19	10			
80	3	L7B	11.10	9.84	17	20	-	-	-	-	-	-	-	F07	70	2.75
		C10	-	-	-	-	9.72	1.61	6.10	5.91	23	26	10			
100	4	L7B	11.77	9.84	22	33	-	-	-	-	-	-	-	F10	102	4.02
		C10	-	-	-	-	11.67	2.48	7.68	7.87	36	47	9			
125	5	L10	12.52	13.98	30	43	-	-	-	-	-	-	-	F10	102	4.02
		C10	-	-	-	-	11.08	2.48	7.68	7.87	43	56	9			
150	6	L10	13.11	13.98	33	46	-	-	-	-	-	-	-	F10	102	4.02
		C10	-	-	-	-	11.67	2.48	7.68	7.87	46	59	9			
200	8	L10	14.88	13.98	52.03	71.87	-	-	-	-	-	-	-	F12	125	4.92
		C12	-	-	-	-	13.43	2.40	9.13	12.20	68	88	9.5			
250	10	C12	-	-	-	-	15.00	2.40	9.13	12.20	90	123	9.5	F12	125	4.92
300	12	C14	-	-	-	-	17.44	3.19	11.02	15.75	154	196	12	F14	140	5.51
350	14	C14	-	-	-	-	18.86	3.19	11.02	15.75	194	227	12	F14	140	5.51
400	16	A2	-	-	-	-	21.50	4.84	12.09	15.75	302	381	17.5	F16	165	6.50
450	18	A2	-	-	-	-	22.48	4.84	12.09	15.75	352	425	17.5	F16	165	6.50
500	20	A2	-	-	-	-	23.86	4.84	12.09	15.75	425	573	17.5	F16	165	6.50
600	24	A3+S3	-	-	-	-	30.91	6.30	14.57	15.75	760	978	52.5	F25	254	10.00

BOLTING & GASKET FOR INSTALLATION

ANSI CLASS 150
ISO PN10-PN25
JIS 10K, 16K, 20K

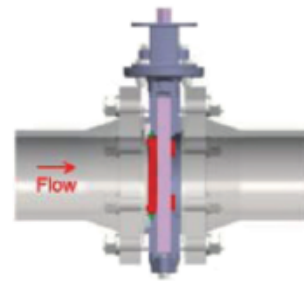
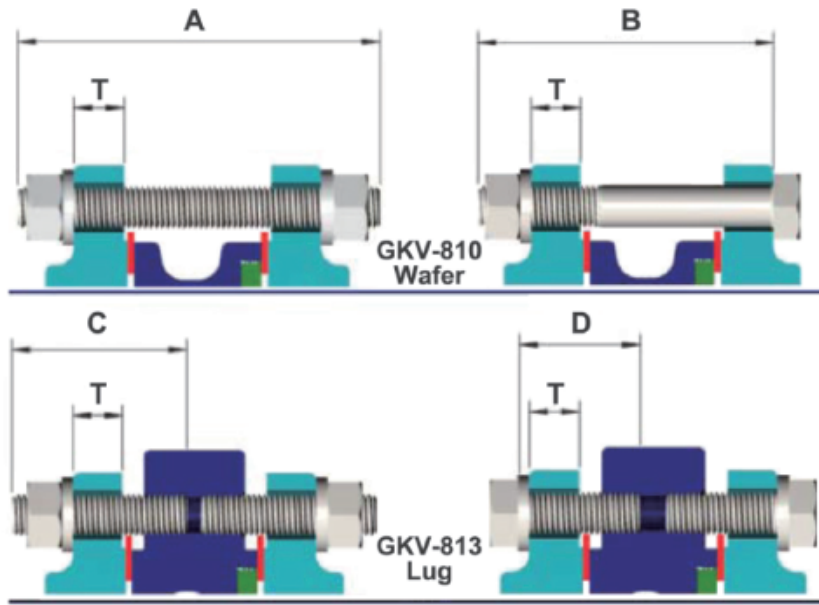

The seals flow can be executed in both directions. The following advantages can be assured while the suggested flow directions is used.

- Minimal start-up torque.
- Reduced seat wear.
- No direct contact between the fluid and the seat.

Size mm inch	PN10						PN16						PN20						PN25						
	Bolt Size	A	B	C	D	T	Bolt Size	A	B	C	D	T	Bolt Size	A	B	C	D	T	Bolt Size	A	B	C	D	T	
65	2.5	M16	130	120	65	45	20	M16	130	120	65	45	20	M16	135	125	70	50	23	M16	135	125	70	50	22
80	3	M16	135	120	65	45	20	M16	135	120	65	45	20	M16	140	130	70	50	24	M16	140	130	70	50	24
100	4	M16	145	130	70	50	22	M16	145	130	70	50	22	M16	145	135	75	55	24	M20	155	140	80	55	24
125	5	M16	145	135	75	50	22	M16	145	135	75	50	22	M20	155	140	75	55	24	M24	175	155	85	60	26
150	6	M20	160	140	80	55	24	M20	160	140	80	55	24	M20	160	145	80	55	26	M24	175	155	90	60	28
200	8	M20	160	145	80	55	24	M20	160	145	80	55	24	M20	170	155	85	60	29	M24	185	165	90	65	30
250	10	M20	175	160	85	60	26	M24	185	165	85	60	26	M24	195	175	95	70	31	M27	200	180	100	70	32
300	12	M20	185	170	90	65	26	M24	200	180	90	70	28	M24	205	185	105	70	32	M27	215	195	110	75	34
350	14	M20	185	170	90	65	26	M24	200	185	90	70	30	M27	220	195	105	75	35	M30	230	205	115	80	38
400	16	M24	220	200	110	70	26	M27	235	215	110	80	32	M27	245	225	125	85	37	M33	265	240	130	95	40
450	18	M24	235	215	115	75	28	M27	265	240	115	90	40	M30	270	240	130	95	40	M33	290	265	145	105	48
500	20	M24	245	230	125	75	28	M30	295	270	125	100	44	M30	290	265	140	95	43	M33	305	280	155	105	48
600	24	M27	290	270	145	85	34	M33	345	320	145	110	54	M33	335	310	165	105	48	M36	360	330	180	120	58

Size mm inch	ANSI B16.5 150LB						JIS10K						JIS 16K&20K						B.S.10 TABLE E						
	Bolt Size	A	B	C	D	T	Bolt Size	A	B	C	D	T	Bolt Size	A	B	C	D	T	Bolt Size	A	B	C	D	T	
65	2.5	5/8	135	125	70	50	22	M16	130	115	65	45	18	M16	130	115	65	45	18	5/8	120	110	60	40	14
80	3	5/8	140	130	70	50	24	M16	130	115	65	45	18	M20	140	125	70	50	20	5/8	120	110	60	40	14
100	4	5/8	145	135	75	55	24	M16	135	120	70	50	18	M20	150	135	75	55	22	5/8	135	120	65	45	17
125	5	3/4	160	145	80	55	24	M20	150	135	75	55	20	M22	160	140	80	55	22	5/8	140	125	70	50	17
150	6	3/4	160	145	80	55	25	M20	155	140	80	55	22	M22	160	145	80	55	24	3/4	145	130	70	50	17
200	8	3/4	170	155	85	60	28	M20	160	140	80	55	22	M22	170	150	85	60	26	3/4	152	135	75	50	19
250	10	7/8	185	170	95	65	30	M22	175	155	85	60	24	M24	190	170	95	65	28	3/4	165	150	85	55	22
300	12	7/8	200	180	100	70	32	M22	185	165	90	60	24	M24	200	185	100	70	30	7/8	185	170	95	65	25
350	14	1	215	195	105	75	35	M22	190	170	95	65	26	M30	220	200	110	80	34	7/8	195	175	95	70	29
400	16	1	240	220	120	80	37	M24	220	205	110	70	28	M30	255	230	130	85	38	7/8	225	205	110	75	32
450	18	1 1/8	265	240	130	90	40	M24	240	220	120	75	30	M30	270	245	135	90	40	7/8	240	225	120	80	35
500	20	1 1/8	285	260	140	90	43	M24	250	230	125	75	30	M30	290	265	145	95	42	7/8	260	245	130	80	38
600	24	1 1/4	330	305	165	100	48	M30	295	270	145	85	32	M36	335	310	170	105	46	1 1/8	325	300	165	100	48

MATERIAL CHART

ANSI CLASS 150LB
PN10, 16, 20, 25
JIS 10K, 16K, 20K

GKV-8	0	008	13	14	34	TL	A	E
TYPE	END	SIZE	BODY	DISC	SHAFT	SEAT	FLANGE	OPTION
TYPE		CODE		SHAFT MATERIAL		CODE		
High Performance Butterfly valve (Teflon Seat)		GKV-810/813		A182 F6a		10		
High Performance Butterfly valve (Teflon + SS316 Seat Fire Sale)		GKV-820/823		A182 F304		34		
				A182 F316		36		
				A182 F316L		6L		
High Performance Butterfly valve		GKV-830/833		A564 630		63		
				XM-19		XM		
ENDCONNECTION		CODE		SEAT MATERIAL		CODE		
WAFER		0		PTFE (GKV-810 ONLY)		TL		
LUG		3		PTFE + 15% GRAPHITE (GKV-810 ONLY)		TG		
FLANGE (Short Body)		6		PTFE + 15% GLASS FIBER (GKV-810 ONLY)		TF		
FLANGE (Long Body)		7		PTFE + A240 316(GKV-820 ONLY)		T6		
				PTFE + 15%GRAPHITE+A240 316 (GKV-820 ONLY)		G6		
				PTFE + 15%FIBER + A240 316 (GKV-820 ONLY)		F6		
				A240 316 (GKV-830 ONLY)		36		
				INCONEL 718 (GKV-830 ONLY)		IC		
SIZE		CODE		FLANGE DRILLING (Please refer to brochure)		CODE		
DN 65 / 2-1/2"		006		ASME B16.5 150LB		A		
DN 80 / 3"		008		ASME B16.5 300LB		B		
DN 100 / 4"		010		ISO 7005 -1 PN10		C		
DN 125 / 5"		012		ISO 7005 -1 PN16		D		
DN 150 / 6"		015		ISO 7005 -1 PN20		E		
DN 200 / 8"		020		ISO 7005 -1 PN25		F		
DN 250 / 10"		025		ISO 7005 -1 PN40		G		
DN 300 / 12"		030		ISO 7005 -1 PN50		H		
DN 350 / 14"		035		JIS 10K		K		
DN 400 / 16"		040		JIS 16K		M		
DN 450 / 18"		045		JIS 20K		P		
DN 500 / 20"		050		B.S.10Table E		N		
DN 600 / 24"		060						
BODY MATERIAL		CODE		DISC MATERIAL		CODE		
A216 WCB		WB		A351 CF8		13		
A351 CF8		13		A351 CF8M		14		
A351 CF8M		14		A351 CF3M		16		
A351 CF3M		16						
DISC MATERIAL		CODE		OPTION		CODE		
A351 CF8		13		Emission Test		E		
A351 CF8M		14		WORK TEMP. >250°C (GKV- 830 ONLY)		H		
A351 CF3M		16		Internal Polished		P		

GKV-9

Triple-offset butterfly valve

Features:

- True triple offset geometry
- Fully bi-directional zero-leakage* shutoff
- Field replaceable metal seat
- Life cycle tested as a bubble-tight bi-directional valve
- Compliance and Specifications: TA-LUFT, ISO 1584-1, BS 6364
- Standard bearing seals
- Self-centering disc
- Available in a wide range of configurations: lug, short (ISO), and long pattern
- Carbon and stainless steel standard; other materials on request

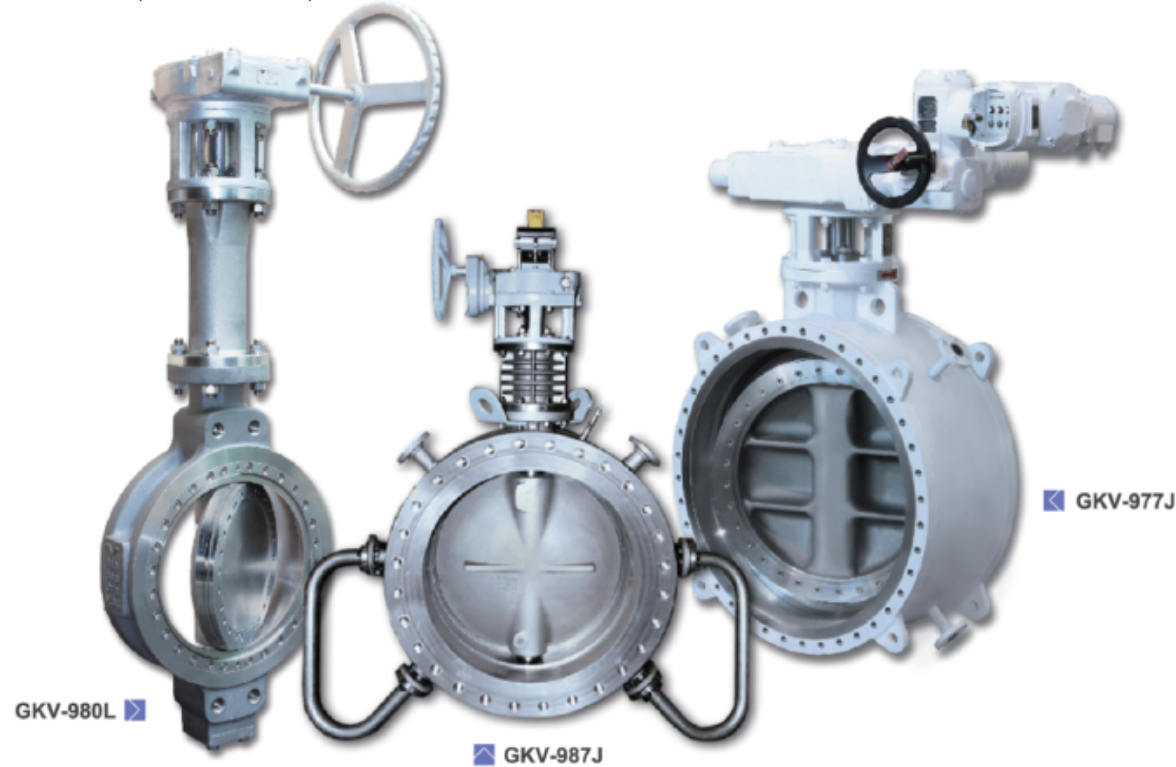

Design specifications:

- Body type: lug, wafer, flanged
- Face-to-face: API 609, ISO 5752
- Fire test: API607, ISO 10497
- Cryogenic: BS 6364
- Explosion-proof: ATEX
- Leakage level: ANSI FCI 70-2-2003 TABLE 1, ISO 5208 RATE D/A ,ANSI/ISA-SP-93
- Flange design: ASME B16.5 Class 150/300/600, ASME B16.47 Class 150/300/600
- VOC Emission: ANSI/ISA-SP-93, TA LUFT, ISO 15848-1/-2
- Note: MSS-SP-25
- Thickness: ASME B16.34
- Pressure: ASME B16.34
- Pressure test: ISO 5208, API 598

Principle of operation

The triple-offset valve provides a bidirectional bubble tight shut-off . This geometry ensures that the disc seal contacts the body seat only at the final shut-off position without rubbing or galling, providing a torque generated resilient seal with sufficient "wedging" to ensure a uniform seal contact.

Offset 1: The shaft is offset behind the seat axis to allow complete sealing contact around the entire seat.

Offset 2: The shaft centerline is offset from the pipe and valve which provides interference free opening and closing of the valve.

offset 3: The seat cone axis is offset from the shaft centerline to eliminate friction during closing and opening and to achieve uniform compressive sealing around the entire seat.

The body in Stellite 21 alloy for long life and easy maintance.

Design and construction accroding to international standards or customer specifications

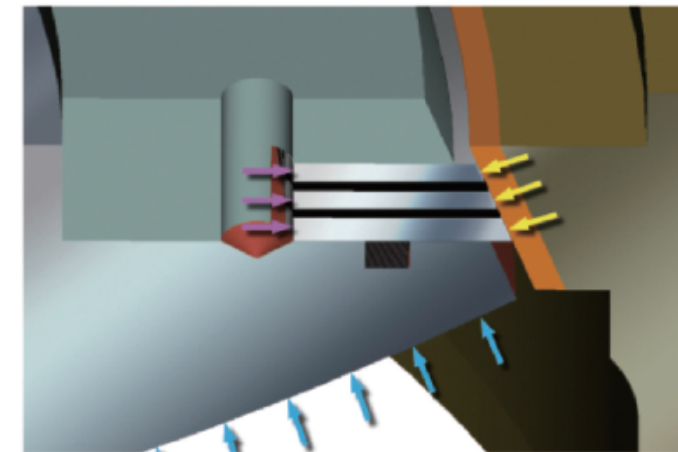

TRIPLE OFFSET GEOMETRY

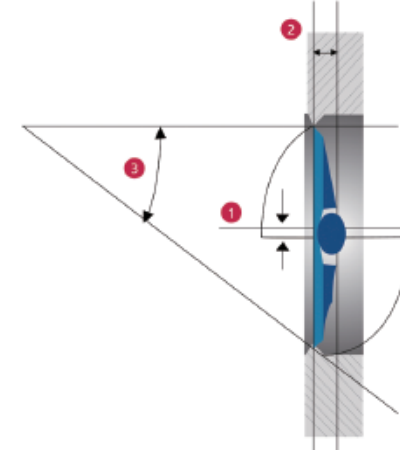

One-piece shaft
Large diameter shaft for safety is connected to the disc close to the bearings to absorb loads with taper pin and/or key to allow for differential expansion due to temperature.

Dustproof design
The resilient seal assures zero leakage of liquids or gases. Resiliency in the seal allows disc movement during thermal cycles while retaining tight shutoff as shown.

Shaft bearings
The shaft is centered on two long bearings, chromed, nitrided, or as CoCr alloy (option) protected against the entrance of solids by bearing seals which are optional on valves.

Double positioner
Double positioner, included anti-thrust and thrust plate, prevent from drooping stem and blow-out proof.

Double Packed with Packing Port

- Double packing with leak-off monitoring purge port.
- Two sets of packing rings, precompressed to 4000 psi (graphite).
- A lantern ring and leak-off connection allows removal of leakage, if any, from bottom packing set.

STANDARD LOW EMISSION STEM SEAL

- Large compression load required
Graphite rings pre-compressed to 4000 psi for effectiveness of all rings. Gland torque must be maintained after installation and in service to levels shown in manuals.
- Stem bearing to assure concentric stem rotation, allowing stem packing to provide maximum sealing effectiveness.
- Two-piece gland with spherical mating surfaces to assure an even packing load over 360°.

compound packing

Prestress load

Double packing

Lantern type ring (optioned)

PRESSURE INLET